

CZTUX87
SURFACE MOUNT
HIGH VOLTAGE
NPN SILICON POWER TRANSISTOR

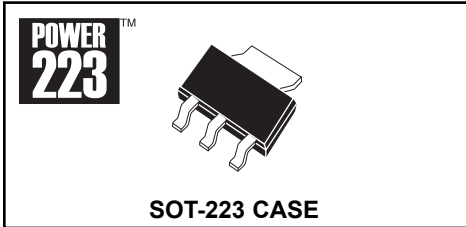

CentralTM

Semiconductor Corp.

DESCRIPTION:

The CENTRAL SEMICONDUCTOR CZTUX87 type is a NPN Silicon Power Transistor epoxy molded in a surface mount package, designed for high voltage switching applications.

MARKING CODE: FULL PART NUMBER

MAXIMUM RATINGS: ($T_A=25^\circ\text{C}$)

	SYMBOL		UNITS
Collector-Emitter Voltage	V_{CEV}	900	V
Collector-Emitter Voltage	V_{CEO}	450	V
Emitter-Base Voltage	V_{EBO}	5.0	V
Collector Current	I_C	0.5	A
Peak Collector Current	I_{CM}	1.0	A
Base Current	I_B	1.0	A
Power Dissipation	P_D	2.0	W
Operating and Storage Junction Temperature	T_J, T_{stg}	-65 to +150	$^\circ\text{C}$
Thermal Resistance	Θ_{JA}	62.5	$^\circ\text{C/W}$

ELECTRICAL CHARACTERISTICS: ($T_A=25^\circ\text{C}$ unless otherwise noted)

SYMBOL	TEST CONDITIONS	MIN	TYP	MAX	UNITS
I_{CEV}	$V_{CE}=900\text{V}, V_{BE}=1.5\text{V}$			100	μA
I_{CEV}	$V_{CE}=900\text{V}, V_{BE}=1.5\text{V}, T_A=125^\circ\text{C}$			1.0	mA
I_{EBO}	$V_{EB}=5.0\text{V}$			1.0	mA
BV_{CEO}	$I_C=30\text{mA}$	450			V
$V_{CE(SAT)}$	$I_C=100\text{mA}, I_B=10\text{mA}$			0.8	V
$V_{CE(SAT)}$	$I_C=200\text{mA}, I_B=20\text{mA}$			1.0	V
$V_{BE(SAT)}$	$I_C=200\text{mA}, I_B=20\text{mA}$			1.0	V
h_{FE}	$V_{CE}=5.0\text{V}, I_C=40\text{mA}$	12			
f_T	$V_{CE}=10\text{V}, I_C=50\text{mA}, f=1.0\text{MHz}$		20		MHz
t_s	$V_{CC}=250\text{V}, I_C=200\text{mA}, I_{B1}=40\text{mA}, I_{B2}=80\text{mA}$		4.5		μs
t_f	$V_{CC}=250\text{V}, I_C=200\text{mA}, I_{B1}=40\text{mA}, I_{B2}=80\text{mA}$		0.5		μs

R2 (17-June 2004)

SOT-223 CASE - MECHANICAL OUTLINE

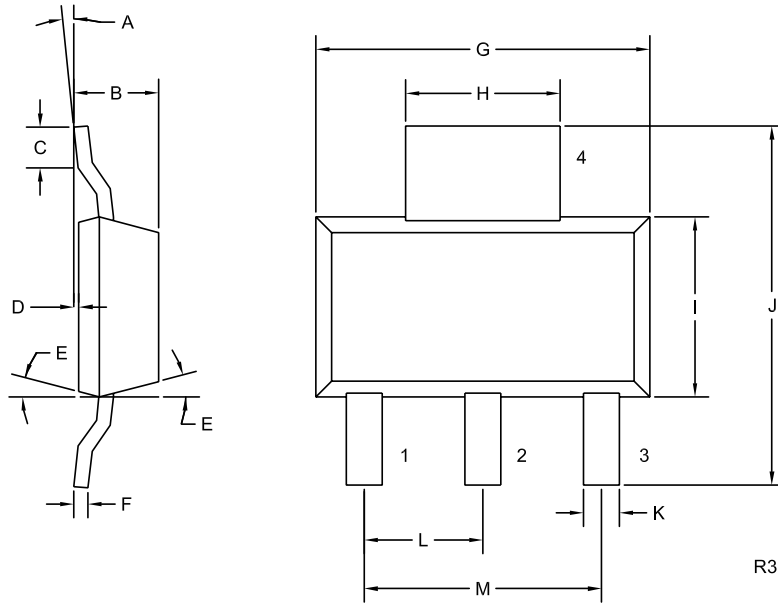

LEAD CODE:

- 1) BASE
- 2) COLLECTOR
- 3) EMITTER
- 4) COLLECTOR

MARKING CODE:

FULL PART NUMBER

SYMBOL	DIMENSIONS			
	INCHES		MILLIMETERS	
	MIN	MAX	MIN	MAX
A	0°	10°	0°	10°
B	0.059	0.071	1.50	1.80
C	0.018	---	0.45	---
D	0.000	0.004	0.00	0.10
E	15°		15°	
F	0.009	0.014	0.23	0.35
G	0.248	0.264	6.30	6.70
H	0.114	0.122	2.90	3.10
I	0.130	0.146	3.30	3.70
J	0.264	0.287	6.70	7.30
K	0.024	0.033	0.60	0.85
L	0.091		2.30	
M	0.181		4.60	

SOT-223 (REV: R3)

R2 (17-June 2004)